

Wind Tunnel Experiment on a Cylindrical Anemometer

by

M. Sanuki

Central Meteorological Observatory

(Received April 28, 1955)

Abstract

An experimental anemometer with three semi-circular cylindrical shells with open ends is tested in wind tunnel of its rotational speed in tilted attitudes. This is to clarify the proposal of I. FUJIMURA to install such type at mountain stations to be free from strong up-wash effect of wind often encountered.

The results are disappointing and the standard three-cup anemometer is found to give rather constant rotational speed despite of up-wash or down-wash.

1. Object

Some thirteen years ago FUJIMURA [1] of Fuji Mountain Station proposed an idea of installing an anemometer with cylindrical shells with open ends hoping to be free from the up-wash effect of wind encountered at mountain stations. He manufactured an experimental anemometer with three semi-circular cylindrical shells with open ends, fitted with anti-freezing liquid injection additionally for winter operation. He did not, however, conduct wind speed measurement thoroughly and could not confirm his statement that such anemometer will measure only the horizontal component of wind in up-wash. The present experiment is to investigate in wind tunnel the rotational speed of the proposed type in up-wash and in down-wash, too.

2. Tested anemometer and method of experiment

Three semi-circular cylindrical shells with open ends are manufactured from thin brass sheet of 0.4 mm thickness. The diameter and length of cylinder are 100 mm respectively. The arm length from the central shaft of rotation to the center line of the cylinder is again 100 mm. These dimensions are in conformity to those of the standard three-cup anemometer the diameter of which is 100 mm. The shells are incorporated with side beads as in the case of cup type, and mounted on the support of the standard cup anemometer as illustrated in Fig. 1.

The anemometer is tilted in the wind tunnel to simulate the up-wash or down-wash. The rotational speed is measured in steady state. The same measurement is carried out also for the standard cup anemometer.

3. Experimental results

The rotational speed of the semi-cylindrical and cup anemometer with no tilt is pictured in Fig. 2. It is somewhat remarkable that the semi-cylindrical anemometer shows only ca. 70% rotational speed N r.p.m. of that of cup type at the same wind speed V m/s, in spite of its larger shell area. This will presumably be due to the open ends of the cylindrical shells.

The rotational speed of tilted anemometer is shown in Fig. 3 for semi-cylindrical one and in Fig. 4 for cup type, both for four wind speeds. The rotational speed is given in fraction of that with zero tilt angle. In Fig. 3 a curve of cosine of the tilt angle θ is given. If the semi-cylindrical anemometer should give precisely the horizontal component of wind speed, the experimented curves must lie on the cosine curve. This is not the case as can be seen from the figure, and the proposal due to FUJIMURA seems to be a little primitive.

The rotational speed of cup type is rather constant as shown in Fig. 4. The statement of FUJIMURA is correct at some large up-wash, probably near 50° (Fig. 3), which region is not tested here.

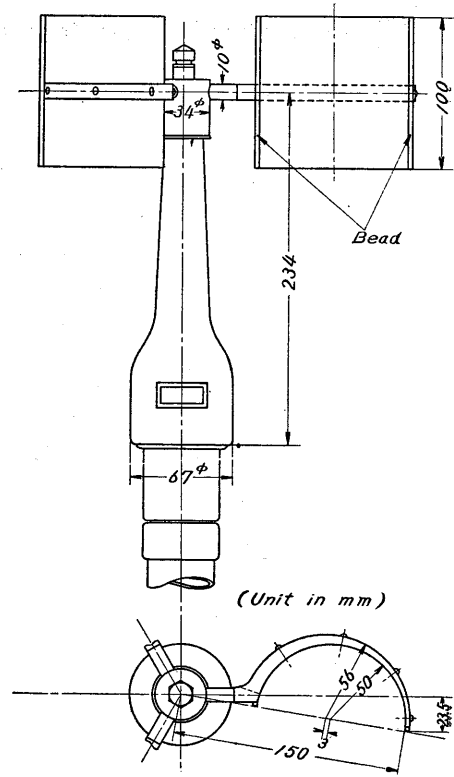

Fig. 1. Semi-cylindrical anemometer.

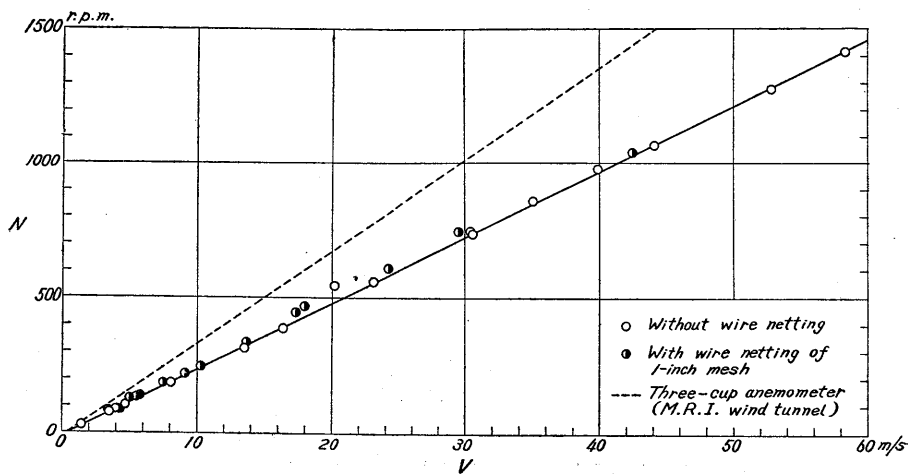

Fig. 2. Rotational speed of the semi-cylindrical anemometer. (C.M.O. wind tunnel).

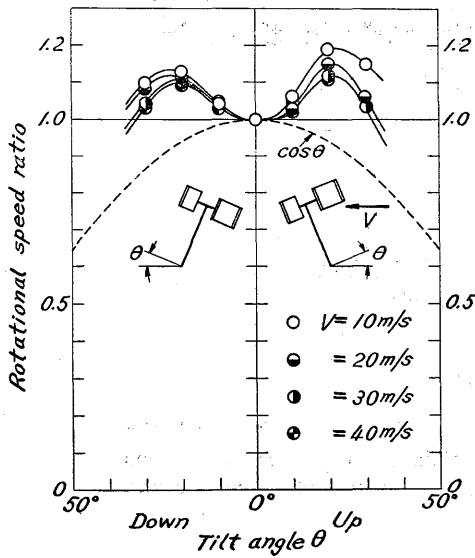

Fig. 3. Rotational speed of tilted cylindrical anemometer (C.M.O. wind tunnel).

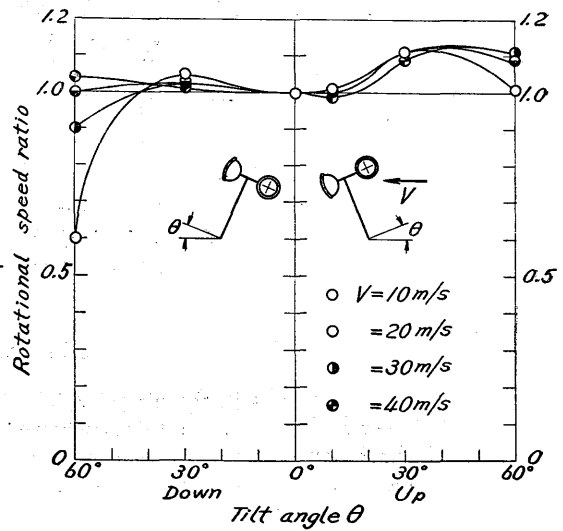

Fig. 4. Rotational speed of tilted three-cup anemometer (C.M.O. wind tunnel).

Acknowledgements—The author is indebted to Mr. G. OKADA, Chief of the Instrument Plant of the Observatory, for the manufacture of the experimental anemometer, and also to Mr. T. SUZUKI for the wind tunnel experiment.

Reference

[1] FUJIMURA, I., 1942: A New Anti-Freezing Anemometer (in Japanese), *Memoirs Cent Met. Obs.*, 19, p. 316.